



Internal Rope Halyard flagpole categories contain multiple Flagpole Truck options. Your flagpole will contain one of the trucks shown below.



External Rope Halyard Stationary Truck



External Rope Halyard Single Revolving Truck

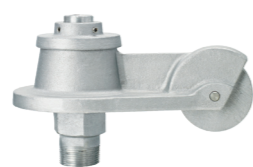

External Rope Halyard Single Revolving Heavy-Duty Truck



External Rope Halyard Double Revolving Truck

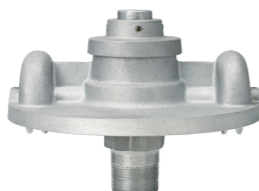

External Rope Halyard Double Revolving Heavy-Duty Truck



External Rope Halyard Single Revolving Ball Truck

**WARNING:** Do not install flagpole near overhead power lines. Always be aware of cable and pipes buried underground. Utility departments should be contacted to confirm that it is safe to dig in the area where flagpole is to be installed. It is advisable to have assistance with flagpole installations. Any flagpole with a 5" diameter base or larger or over 25' in length may require lifting device. Following review of instructions, the purchaser of the flagpole should determine if they are qualified to perform installation or they should obtain the services of a professional sign/flagpole installation company. Due to various methods of installation used by installers, Concord American Flagpole cannot be liable for structural damage or injury occurring during flagpole assembly and installation.

**Section 1. Foundation Installation**

Prepare the foundation hole for Ground Sleeve or Shoe Base installations as detailed in following instructions. NAAMM's **Metal Flagpole Manual** offers basic suggestions on foundation requirements in firm, dry soil using dry tamped sand and 3000 PSI concrete (See Page 6).

**NOTE:** Soil conditions vary by site and the listed dimensions are considered minimum dimensions for foundations in firm dry soil.

**Exact foundation requirements should be verified by a Structural Engineer with knowledge of soil conditions in your area.**

Flagpole Ground Sleeves are available in either PVC or Corrugated Steel with Steel Lighting Spike and Setting Plate (**PART G**). Refer to diagrams on Page 6 for foundation illustrations.

**1A. PVC Ground Sleeves**

A proper base in the bottom of the foundation hole is required for PVC Sleeves. Base should contain a combination of gravel and sand totaling approximately 12". The level of gravel, used for drainage purposes, should be approximately 10" with a 2" layer of tamped sand capping the stone.

\* Sand prevents damp concrete from blending with gravel when poured into hole \*

Install PVC Ground Sleeve in center of hole with the top of the sleeve 2" above grade. Make sure the bottom of the tube is worked well into the sand. Plumb Ground Sleeve tube vertically and brace so that it cannot move during concrete pouring. Insert a level into the sleeve to ensure it is vertical. Ground Sleeves are oversized to allow for adjustments using wood wedges and dry, tamped sand (by others).

Pour concrete, continuing to verify vertical plumb and trowel to desired finish. Keep the inside of sleeve dry and free of debris by covering the opening. Allow concrete to cure for a *minimum* of 24 hours.

**1B. Corrugated Steel with Steel Lighting Spike and Setting Plate**

Set ground sleeve in center of hole, pushing corrugated sleeve rod into the ground until ground sleeve steel support plate is resting on the bottom of the hole. The top of the sleeve should be 2" above grade. When concrete is poured, it will fill in the area between the setting plate and the base plate. Carefully plumb the ground sleeve tube vertically and brace it so that it cannot move while concrete is being poured. Use a level inserted into the sleeve to ensure it is vertical.

Slowly pour concrete, continuing to verify vertical plumb. Care should be taken that the pouring of the concrete is not at a rate that might cause the ground sleeve to "float up" as the concrete goes under the base plate (refer to drawing). Trowel to desired finish. Keep the inside of the sleeve dry and free of debris by covering the opening. Allow concrete to cure for a *minimum* of 24 hours.

**1C. Shoe Base Foundation**

All Concord American Flagpole Shoe Base Flagpoles include steel Anchor Bolts and stainless steel attaching hardware. Full size, 1:1 mounting templates with full instructions are shipped with the hardware.

**Section 2. Shaft Preparation**

Flagpole should be assembled with base as close as possible to final installation location. Flagpole shaft configuration can be either 1-Piece or Multi-Piece.

**2A. 1-Piece Flagpoles**

Place flagpole shaft on sawhorses in order to attach components. Proceed to Section 3.

**2B. Multi-Section Flagpole**

Multiple section flagpoles are designed and fabricated with self-aligning jam sleeve for each flagpole joint. Joints incorporate tight tolerances for a strong and permanent field assembly. Inspect shaft sections for damage before any assembly.

**NOTE:** Disassembly of shaft sections, after assembly, without damage is extremely difficult or impossible. No hardware should be installed until shaft sections are completely assembled. The following information is intended to be a helpful guide to the installer.

Carefully lay flagpole sections out in proper order. Set bottom section on blocks, saw horses, or short pieces of larger diameter PVC pipe in a horizontal position with base of the lower section against an immovable object. Rotate pieces until match marks can be seen. (See Match Mark illustration)  
For flagpoles with 3 or more sections, start with bottom sections. Sections must be straight and level while sliding together.

**NOTE:** All multi-piece joints are custom fit from factory. Once fit, each section is stamped with both aligning match marks and corresponding numbers. Before proceeding, verify that the numbers are the same. If they do not match **DO NOT PROCEED**, as sections will not properly fit together. If you have purchased more than one flagpole, verify that all sections are grouped with correct matching numbers. Sections are *not interchangeable*.

Carefully clean all mating surfaces outside of jam sleeve and inside bottom area of section into which the jam sleeve will be fitted. Inspect and remove debris or burrs.

Cover jam sleeve and inner area of section that it will be going in to with a light layer of liquid soap.

\*Do not use grease, oil or other petroleum products as they can stain flagpole over time\*

Keep finished surfaces of shaft free from hand prints and excess lubricants. Gently slide sections of flagpole, with match marks in line with lower section, onto jam sleeve as far as possible without forcing the two pieces together. Rolling flagpole 180° with every 2" to 3" may facilitate easier fit. If extreme difficulty is experienced while fitting the first 6 inches together, pull apart and cool the male section with ice for several minutes. With pieces in line, place a 4x4 block of wood against top of flagpole, to absorb direct shock, and firmly strike wood to drive the sections together. Excessive force is not necessary. If pieces are not coming together, contact your dealer. If flagpole is a 3-piece unit, clean, lubricate and install the next section in same manner as above.

**Section 3. Hardware Assembly**

When working with threaded aluminum components, a light coat of an anti-seize compound (available at most hardware stores) is recommended.

**3A. Truck Assembly**

External Halyard trucks (**PART B**) come in a variety of configurations including slip-on Stationary and Ball Trucks, Revolving Trucks in Single and Double Halyard designs, and Revolving Ball Truck options. Revolving Truck and Ball Truck options are designed with 1-1/4" NPT Spindles which are installed into a threaded insert welded into the top of the flagpole.

**Stationary Trucks/Ball Trucks** - String halyard (rope) over cast aluminum truck pulley. Slide truck

over the top of the flagpole, rotating the truck to align pulley in desired direction. The most common direction is directly over the cleat, but locations allowing for installations aligning truck direction with the prevailing wind may also be desired. After determining the direction of the truck, secure it to the top of the flagpole by tightening the set screws with an Allen head wrench.



**Revolving Trucks/Ball Trucks** - Carefully check Rotating Truck Assembly and Flagpole Top Insert threads for burrs or irregularities. Thread Rotating Truck Assembly Spindle into top

of flagpole. Do not use epoxy on the spindle of the truck. These threads are 1 1/4" NPT (National Pipe Thread). Extreme care should be taken to avoid cross threading the components, as Aluminum threads can be easily damaged.

Snug spindle using appropriately sized wrench. Threads are tapered and manufactured in such a manner that over half of spindle threads should go into shaft before it is fully seated. If damage occurs during this process, contact your dealer.

**3B. Ornament Assembly**

Unpack flagpole ball, eagle, or finial (**PART A**) and thread jam nut up threads. Epoxy (Loc-Tite type product) is recommended. After applying small amount of epoxy, carefully thread ball into top of truck. Grip spindle/rod with vise grips and tighten. Do not grip ball to tighten. Ornament shaft should protrude approximately 1/4" inside truck cover. After ball is in place, use properly sized wrench to jam nut against top of truck assembly. If your truck incorporates a set screw, use an Allen wrench to tighten screw into Ball Stem. Optional eagles and finials are attached in the same manner. Consideration must be given to the direction that you want the ornaments to face. Eagles should always face in the same direction as the flag. Reinstall the top half of the truck ensuring that the center pulley aligns with the center of the spindle.

**3C. Cleat**

Install the cleat(s) (**PART E**) to 1/4"-20NC tapped holes in flagpole. Bolt holes located approximately 4'-1/2" above the point that flagpole will be above ground level. Slide provided stainless steel screws through the cleat and start them into the pre-drilled holes and snug with hex wrench. Be careful not to cross thread any threaded component or over tighten.

**INSTALLATION INSTRUCTIONS**

**EXTERNAL ROPE HALYARD FLAGPOLE**

**Estate (ESS)**

**Continental (ESR and EDR)**

**Xtreme (XESR)**

*Read these instructions completely before any installation is started. Pay close attention to all safety concerns. In the unlikely event that you encounter any difficulty, or if a part is missing from the parts diagram, please contact the dealer or representative from which the flagpole was purchased.*

**Inspection of the Shaft and Components**

Inspection of the shaft for shipping damage should be done at the time of receipt. Flagpole packaging is carefully chosen to protect the finish during transportation. Any tear in the package should be inspected for possible damage. If the flagpole is delivered showing signs of freight damage, shipment should be refused. Dealer or representative from which the flagpole was purchased should be immediately contacted. Verify that all standard or substituted parts have been received in acceptable condition. If there is any damage to the shaft or components, do not continue with the installation without first contacting the dealer. To continue with the installation signifies the acceptance of the product in the condition received. Concord American Flagpole will not be responsible for later installation expenses for missing or damaged parts.

**WARNING:**

**NOTE:** To prevent staining, the flagpole must be stored in a dry place OR all packaging must be removed immediately after receiving shipment. If the flagpole gets wet with the packaging still on it, the flagpole may develop stains as it dries. Once packaging is removed, the flagpole should be stored off the ground on blocks until installation.



### 3D. Halyard

Feed rope halyard (**PART D**), around truck pulley (**PART B**) and down toward the bottom of the flagpole as far as they will reach. Size the halyard below the cleat based on the amount of halyard desired to wrap around the cleat. Cut off extra length and very carefully fuse the end of the halyard with a hot blade or flame. Tie ends of halyard together with square knot to form complete loop. Install flagsnaps and neoprene covers (**PART C**) at equal distance on either side of knot to accommodate flag size. Refer to parts diagram for proper flagsnap attachment.

### 3E. Collar

Before standing flagpole, gently slide flash collar (**PART F**) up from bottom and tape it out of the way near cleat. Use of protective wrapping around shaft at this location will provide protection to the finish during installation process.

### Section 4. Standing The Flagpole

When placing flagpole in setting tube, consideration should be given to turning of shaft so that stationary, non-revolving truck assemblies face direction which is opposite from direction of project location's prevailing wind. This will increase the chances of the wind and flag flowing in the same direction. If a revolving truck assembly is used, shaft direction is not important.

The flagpole should be positioned near foundation. Stand flagpole into previously installed ground sleeve (Ground Set Installation) or onto anchor bolts (Shoe Base Installation). This may require use of a crane or backhoe for larger flagpoles. Professionals experienced in such installations should perform rigging and lifting. During lift, keep clear of area and reach of flagpole path. Do not pass flagpole overhead.

**Multiple-Piece Flagpoles** - When installing multi-piece flagpoles, extra care must be used when setting it into sleeve. Before standing flagpole, make certain that the joints are fully seated and that shaft is straight.

*\*DO NOT stand flagpole that is not properly assembled and straight\**

Arrange lift rigging in such a way that flagpole sections are supported from bottom of flagpoles so that flagpole joints are pushed together, not pulled apart, during lift. Keep clear of power lines.

**NOTE: Flagpole joint IS NOT designed to support the weight of bottom or middle section of flagpole when raising multi-sectional flagpole. ALWAYS CHOKE MULTIPLE SECTION FLAGPOLE BELOW LOWEST JOINT AS A SAFETY PRECAUTION.**

### 4A. Ground Set

Flagpoles with spacing between shaft and inside of setting tube, insert flagpole into ground sleeve (galvanized corrugated 16-gauge steel or PVC tube) and plumb flagpole with wooden wedges (by others).

Slowly fill void between flagpole and ground sleeve with washed and screened, dry tamped sand. *Do not use silica sand.* Fill ground sleeve 6" to 8" at a time and tamp as you fill. Fill ground sleeve with sand to about 2" from top, then cap with waterproof compound (by others). Refer to NAAMM's **Metal Flagpole Manual** illustration (See Page 6).

### 4B. Shoe Base

After placing flagpole on top of anchor bolts, install flat washer, lock washer, and hex nut. Tighten nut and verify that all threads are fully engaged. Refer to full installation instructions located on Bolt Circle Template shipped with anchor bolts. **NOTE: Installation using "double nuts" is not recommended by Concord American Flagpole.**

### Section 5. Finishing The Installation

After waterproof compound has dried (Ground Set Installations) or nuts have been tightened (Shoe Base Installations), slide flash collar (**PART F**) down into position and caulk joint with matching color silicone to seal space between flagpole and flash collar.

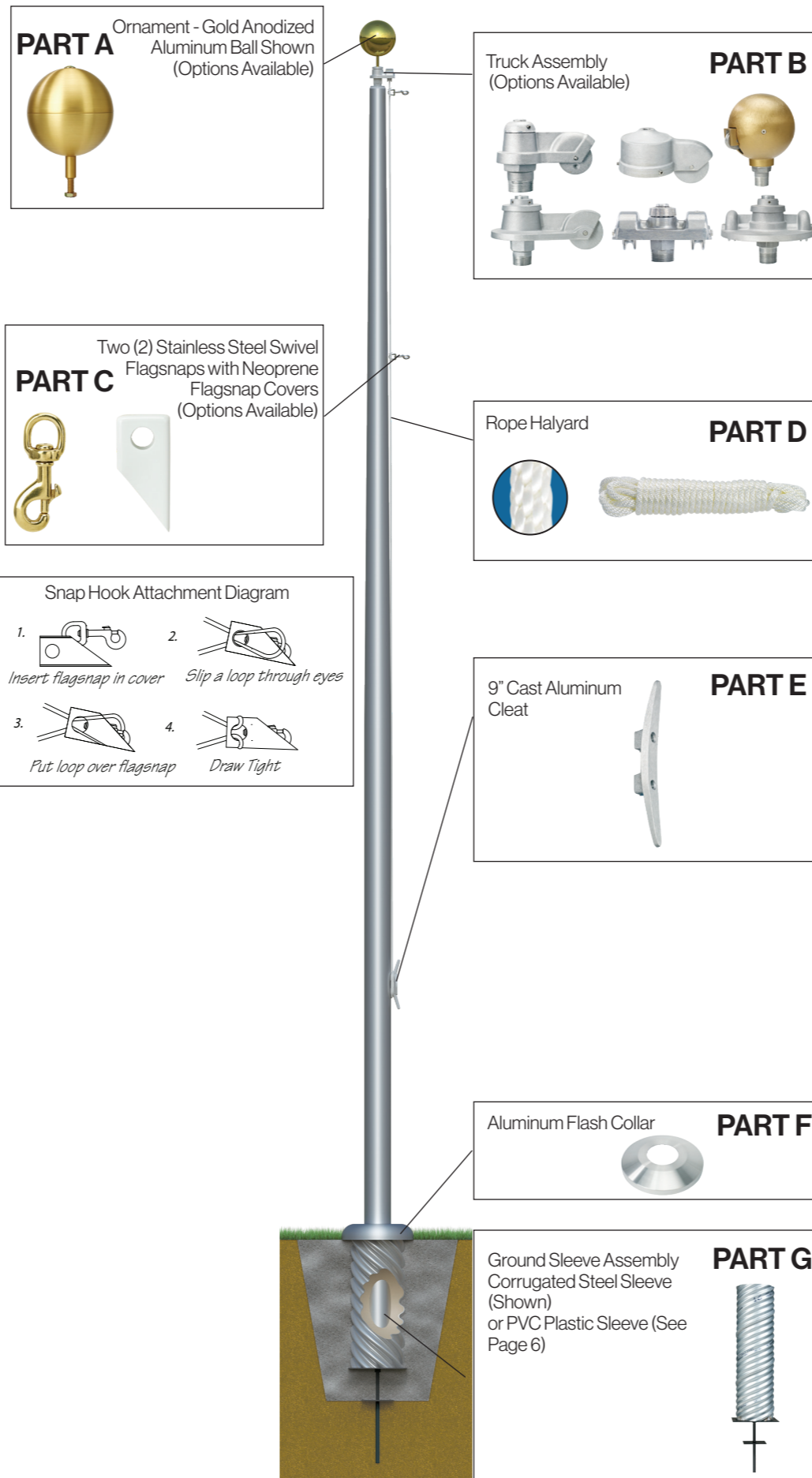

## FOUNDATION INSTALLATIONS

NAAMM's **Metal Flagpole Manual** offers basic suggestions on foundation measurements in firm, dry soil only using dry tamped sand and 3000 PSI concrete. These dimensions should be considered as minimum recommendations as soil conditions vary by site.

**Exact foundation requirements should be verified by a Structural Engineer with knowledge of soil conditions in your locality.**

### GROUND SLEEVE INSTALLATION

NAAMM Minimum Recommended Foundation Measurements (Structural Engineering Requirements for Foundations Verified By Others.)

#### Ground Sleeve with Steel Lighting Spike Installation

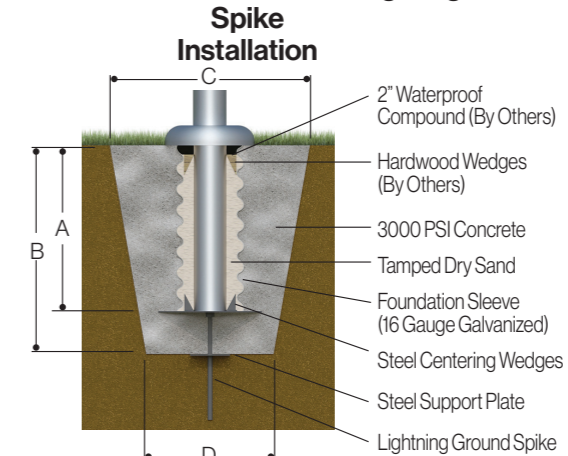

#### PVC Ground Sleeve Installation

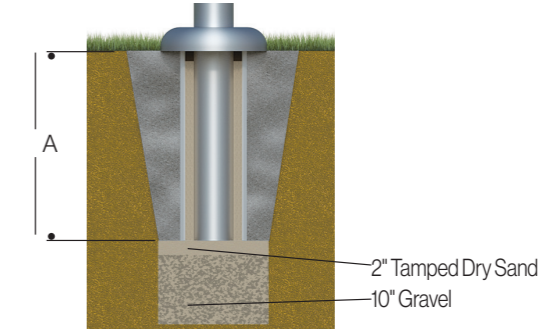

EXPOSED MOUNTING HEIGHT	Ground Set			
	A	B	C	D
20'-0"	2'-0"	2'-6"	30"	24"
25'-0"	2'-6"	3'-0"	36"	24"
30'-0"	3'-0"	3'-6"	36"	24"
35'-0"	3'-6"	4'-0"	36"	30"
40'-0"	4'-0"	4'-6"	45"	36"
45'-0"	4'-6"	5'-0"	45"	36"
50'-0"	5'-0"	5'-6"	50"	42"
60'-0"	6'-0"	6'-6"	60"	48"
70'-0"	7'-0"	7'-6"	60"	48"
80'-0"	8'-0"	8'-6"	72"	48"

### SHOE BASE FOUNDATION

(Structural Engineering Requirements For Foundations Provided By Others.)

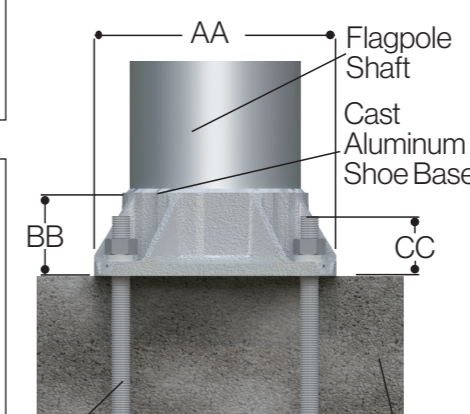

3000 PSI Concrete

BUTT DIAMETER	Shoe Base				
	AA BASE SQUARE	BB BASE HEIGHT	CC BOLT PROJECTION	BOLT DIAMETER	BOLT CIRCLE DIAMETER
4"	7-1/2"	3"	2"	3/4"	6-1/2" - 8"
5"	7-1/2"	3"	2"	3/4"	7 1/2" - 8"
6"	9-3/4"	3-1/2"	2-3/4"	1"	9"-10"
7"	10-1/2"	3-11/16"	2-3/4"	1"	10"-11"
8"	11-1/4"	3-15/16"	2-3/4"	1"	11"-12"
10"	14"	4-7/8"	3-1/4"	1"	14"-15"
12"	17"	8"	3-3/4"	1-1/4"	16"-18"

Shoe Base Foundation Installation

